

QT-KTS - NO THERMOSTAT



- » Simple to Mount
- » High Switching Performance
- » Large Setting Range
- » Small Size
- » Potential free contact



Industrial Grade



DIN Rail Mount



2 Years Warranty

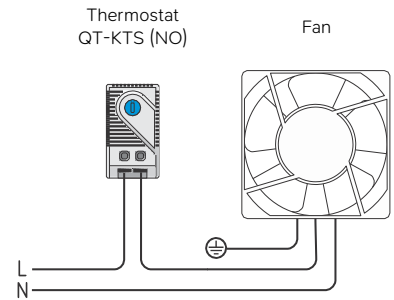

TECHNICAL PARAMETER

Setting Range	0 to +60°C
Sensor Element	Thermostatic Bimetal
Type	Normally Open
Contact Type	Snap-action Contact
Contact Resistance	<10mΩ
Service Life	100,000 cycles
Max. Switching Capacity	250VAC, 10 (2) A / 120VAC, 15 (2) A DC 30W at 24VDC to 72VDC
EMC	Acc. to EN 55014-1-2, EN 61000-3-2, EN 61000-3-3
Connection	2-pole terminal, clamping torque 0.5Nm max. rigid wire 2.5mm ² , stranded wire 1.5mm ² (with wire end ferrule)
Connection Casing	Plastic according to UL94 V-0, Light Grey
Mounting	Clip for 35mm DIN rail, EN 50022
Operating Temperature	-20 To +80°C (-4 to +176°F)
Operating Humidity	max. 90% RH (non-condensing)
Dimensions	60 x 33 x 43mm
Weight	65 gm
Protection Type	IP20 / I (Earthed)
Certification	CE, RoHS Compliance

DIMENSIONS

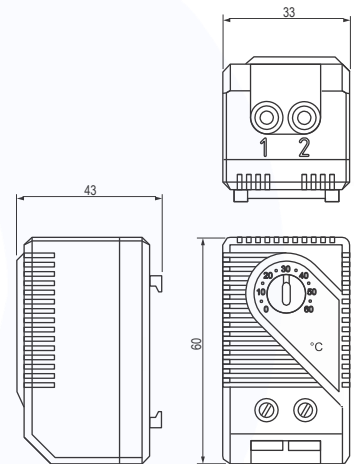

WIRING DIAGRAM

